

MSM6544

42-DOT LCD DRIVER

GENERAL DESCRIPTION

The MSM6544 is a 42-segment duplex driver which can drive the LCD panel up to a maximum of 84 segments.

Since the package is a 56-pin small QFP, an LCD module can be compactly configured. An internal RC oscillator is provided for ease of use.

FEATURES

- Power supply voltage (V_{DD}): 3 to 6V
- LCD driving voltage : 3 to V_{DD}
- Operating temperature : -40 to $+85^{\circ}\text{C}$
- Applicable LCD panel : 1/2 duty, 84 segments (Max)
- Data transmitting clock : 4 MHz (Max)
- Package:
56-pin plastic QFP (QFP56-P-910-0.65-K) (Product name : MSM6544GS-K)

BLOCK DIAGRAM

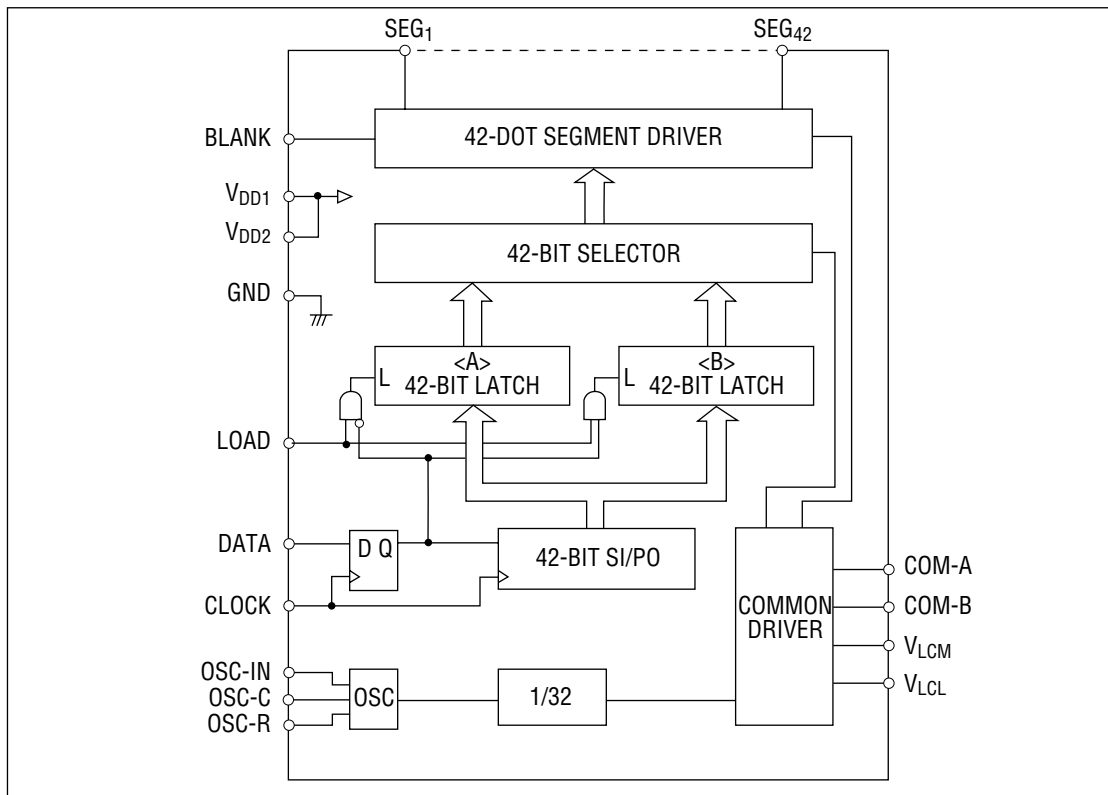

PIN CONFIGURATION (TOP VIEW)

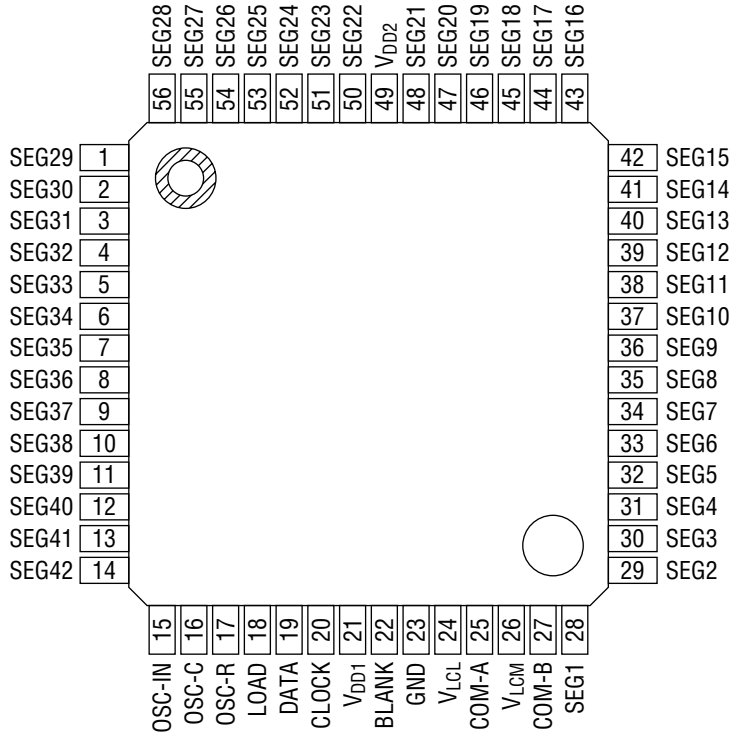

56-Pin Plastic QFP

PIN DESCRIPTIONS

- **OSC-IN, OSC-C, OSC-R**

An RC oscillator circuit for 3-pin type can be configured. Since the OSC-IN pin is in a high input impedance state, it is susceptible to noise.

- **DATA-IN**

This is the display data input. When this pin is at "H" level, the segments are turned on and when at "L" level, the segments are turned off.

- **CLOCK**

Pin for clocking display data in. Display data is shifted on the rising edge of the clock pulse.

- **LOAD**

This is the signal for latching the shift register data. When this pin is set at a "H" level, the shift register data is transmitted to LATCH <A> or LATCH .

- **SEG1 - SEG42**

These pins drive the LCD segments.

- **COM-A, COM-B**

These pins drive the LCD commons. COM-A and COM-B correspond to LATCH <A> output and LATCH output, respectively.

- **V_{DD2}**

This is connected to the V_{DD1} pin internally.

- **V_{LCM}**

This is the center bias pin of the LCD. Supply the middle voltage between V_{DD} and V_{LCL}.

- **V_{LCL}**

This is the power supply pin of the LCD driver. The contrast of the LCD can be adjusted by changing the voltage at this pin, but do not set the voltage less than the GND level.

- **BLANK**

This pin is used to test the all segment outputs (SEG₁ to SEG₄₂). All segment outputs are turned off when this pin is set to "H" level. The display returns to the condition before the pin was set to "H" level.

- **V_{DD1}, GND**

These are power supply voltage and ground pins.

ABSOLUTE MAXIMUM RATINGS

Parameter	Symbol	Condition	Rating	Unit
Supply Voltage	V_{DD}	$T_a = 25^\circ\text{C}$	-0.3 to +6.5	V
Input Voltage	V_I	$T_a = 25^\circ\text{C}$	GND-0.3 to $V_{DD} + 0.3$	V
Storage Temperature	T_{STG}	—	-55 to +150	$^\circ\text{C}$

RECOMMENDED OPERATING CONDITIONS

Parameter	Symbol	Condition	Range	Unit
Supply Voltage	V_{DD}	—	3 to 6	V
Operating Temperature	T_{op}	—	-40 to +85	$^\circ\text{C}$
LCD Driving Voltage	V_{LCD}	$V_{DD} - V_{LCL}$	3 to V_{DD}	V

OSC Circuit

Parameter	Symbol	Condition	Min.	Typ.	Max.	Unit	Applicable Pin
Oscillation Resistance	R_0	—	10	—	68	$k\Omega$	OSC-R
Oscillation Capacitance	C_0	Film capacitor	0.001	—	0.047	μF	OSC-C
Current Control Resistance	R_1	—	33	—	220	$k\Omega$	OSC-IN
Common Signal Frequency	f_{COM}	—	25	—	250	Hz	COM-A COM-B

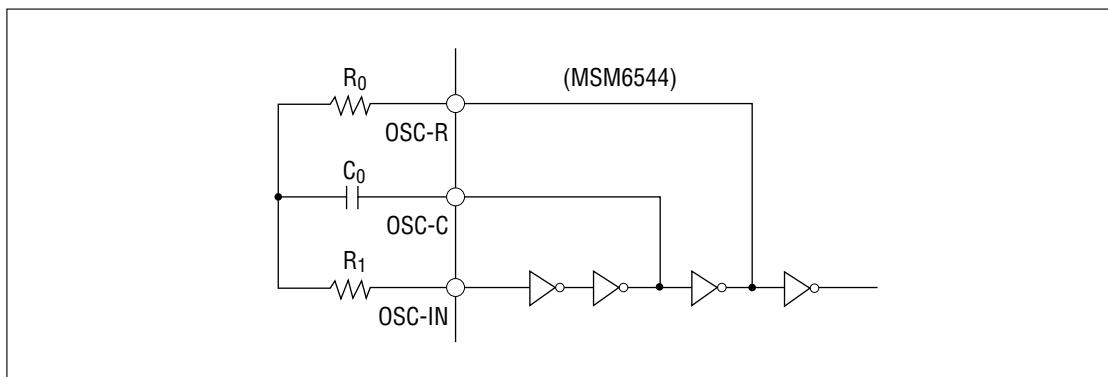

ELECTRICAL CHARACTERISTICS

DC Characteristics

($V_{DD} = 5.0V$ $T_a = -40$ to $+85^\circ C$)

Parameter	Symbol	Corresponding Pin	Condition	Min.	Typ.	Max.	Unit
"H" Input Voltage	V_{IH}	BLANK LOAD DATA CLOCK OSC-IN	—	3.6	—	V_{DD}	V
"L" Input Voltage	V_{IL}		—	GND	—	1.0	V
Input Leakage Current	I_{LI}		$V_I = 5.0V/0V$	—	—	± 1	μA
"H" Output Voltage	V_{OH}	OSC-R OSC-C	$I_O = -200\mu A$	4.5	—	—	V
		All segment outputs	$V_{LCM} = 2.5V$ $V_{LCL} = 0V$ $I_O = -30\mu A$	4.8	—	—	V
		COM-A COM-B	$V_{LCM} = 2.5V$ $V_{LCL} = 0V$ $I_O = -150\mu A$	4.8	—	—	V
"M" Output Voltage	V_{OM}	COM-A COM-B	$V_{LCM} = 2.5V$ $V_{LCL} = 0V$ $I_O = \pm 150\mu A$	2.3	—	2.7	V
"L" Output Voltage	V_{OL}	OSC-R OSC-C	$I_O = 200\mu A$	—	—	0.5	V
		All segment outputs	$V_{LCM} = 2.5V$ $V_{LCL} = 0V$ $I_O = 30\mu A$	—	—	0.2	V
		COM-A COM-B	$V_{LCM} = 2.5V$ $V_{LCL} = 0V$ $I_O = 150\mu A$	—	—	0.2	V
Segment Output Impedance	R_{SEG}	All segment outputs	$V_{LCM} = (5+V_{LCL})/2$ $V_{LCL} = 0$ to $2V$	—	—	10	$k\Omega$
Common Output Impedance	R_{COM}	COM-A COM-B	$V_{LCM} = (5+V_{LCL})/2$ $V_{LCL} = 0$ to $2V$	—	—	1.5	$k\Omega$
Static Supply Current	I_{DD1}	V_{DD}	Fix all inputs to V_{DD} or GND	—	—	100	μA
Dynamic Supply Current	I_{DD2}		No load $R_0 = 47k\Omega$ $C_0 = 0.0047\mu F$ $R_1 = 150k\Omega$	—	0.22	0.5	mA

Switching Characteristics

($V_{DD} = 3.0$ to $6.0V$, $T_a = -40$ to $+85^\circ C$)

Parameter	Symbol	Corresponding Pin	Condition	Min.	Max.	Unit
Clock Pulse Frequency	f_ϕ	CLOCK	—	—	4	MHz
Clock Pulse "H" Time	$t_{\phi H}$		—	100	—	ns
Clock Pulse "L" Time	$t_{\phi L}$		—	100	—	ns
Data Setup Time	$t_{D-\phi}$	DATA	—	80	—	ns
Data Hold Time	$t_{\phi-D}$	CLOCK	—	40	—	ns
Load Pulse "H" Time	t_L	LOAD	—	100	—	ns
Clock-Load Timing	$t_{\phi-L}$	LOAD	—	100	—	ns
OSC-IN Input Frequency	f_{osc}	OSC-IN	—	—	20	kHz

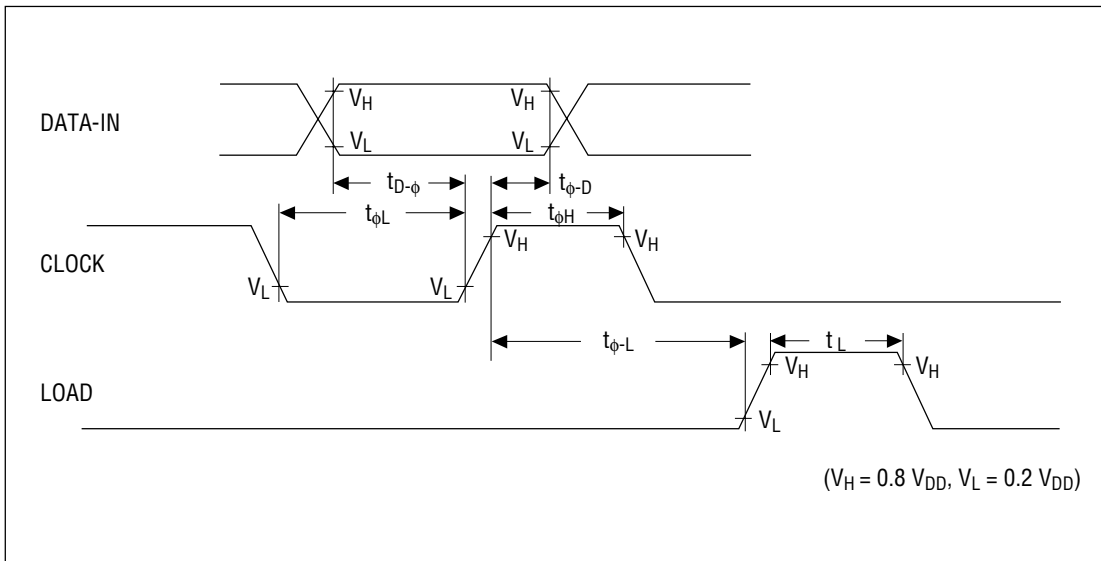

Data Input Timing

• DATA input timing for COM-A

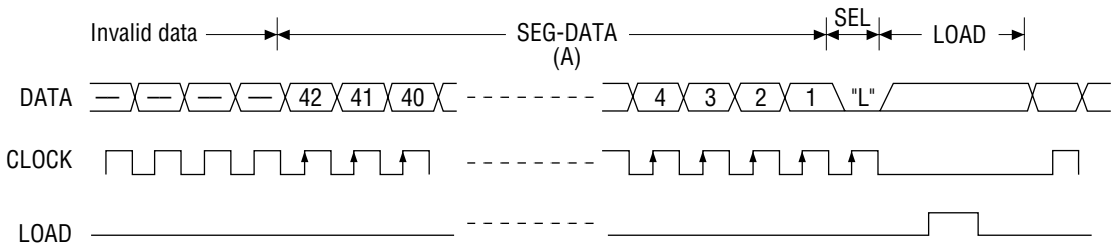

• DATA input timing for COM-B

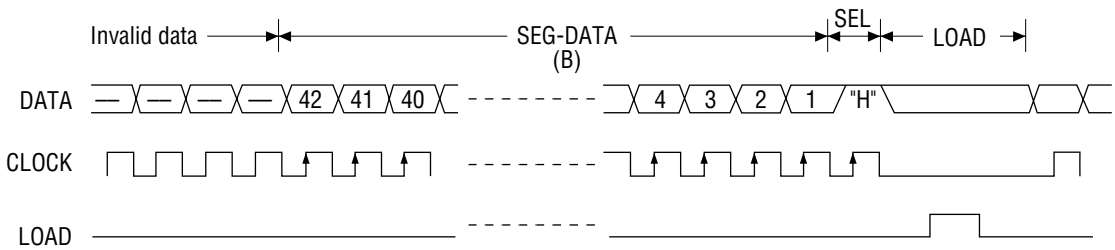

Output Waveforms

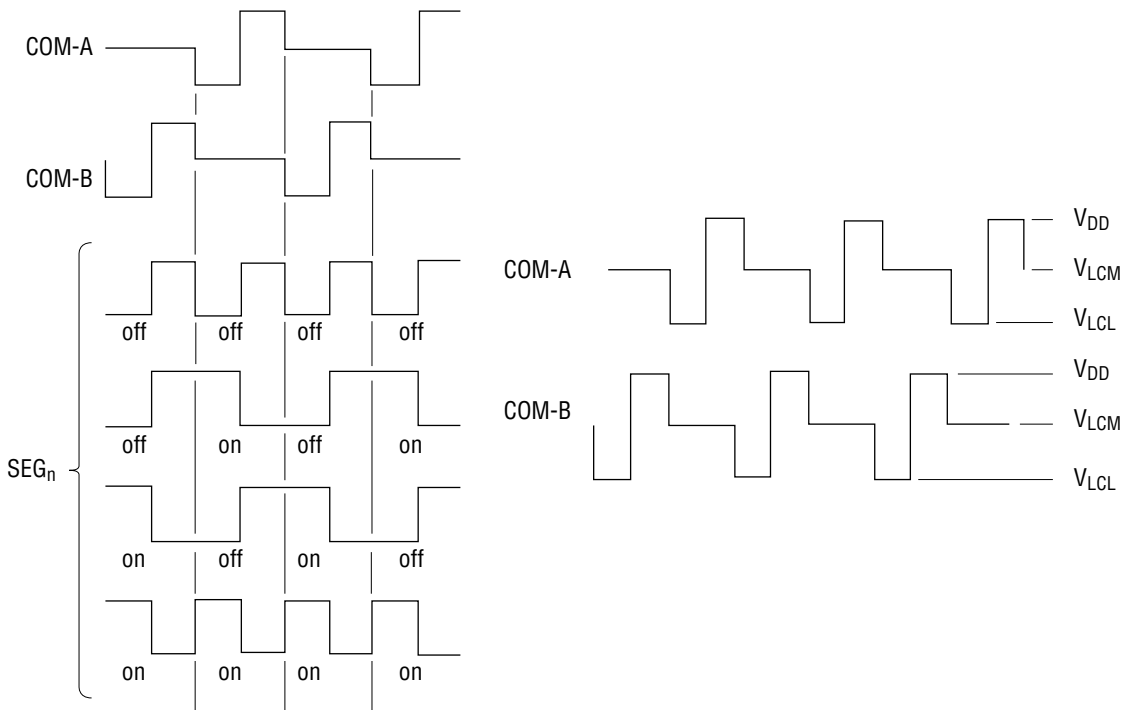

FUNCTIONAL DESCRIPTION

Data Input

The data input consists of the following three timing sections:

- i) SEG-DATA section (42-bit)
- ii) SEL bit section (1-bit)
- iii) LOAD section

A total of 43 bits of 42-bit segment data and 1-bit select bit are taken in the 43-bit shift register at the rising edge of the clock.

The segment data corresponds to "L" (segment OFF) and "H" (segment ON). Input the segment data from SEG42 to SEG1 in this order.

The select bit following the segment data is a bit used to specify the transmit destination of the segment data. The selection is performed as follows.

"L" : LATCH <A> ; corresponds to COM-A

"H" : LATCH ; corresponds to COM-B

The data from the shift register to LATCH <A> or LATCH is transmitted when the LOAD pin is at the "H" level.

The indication corresponding to the transmit destination latch is also changed at the same time that data is transmitted.

APPLICATION CIRCUITS

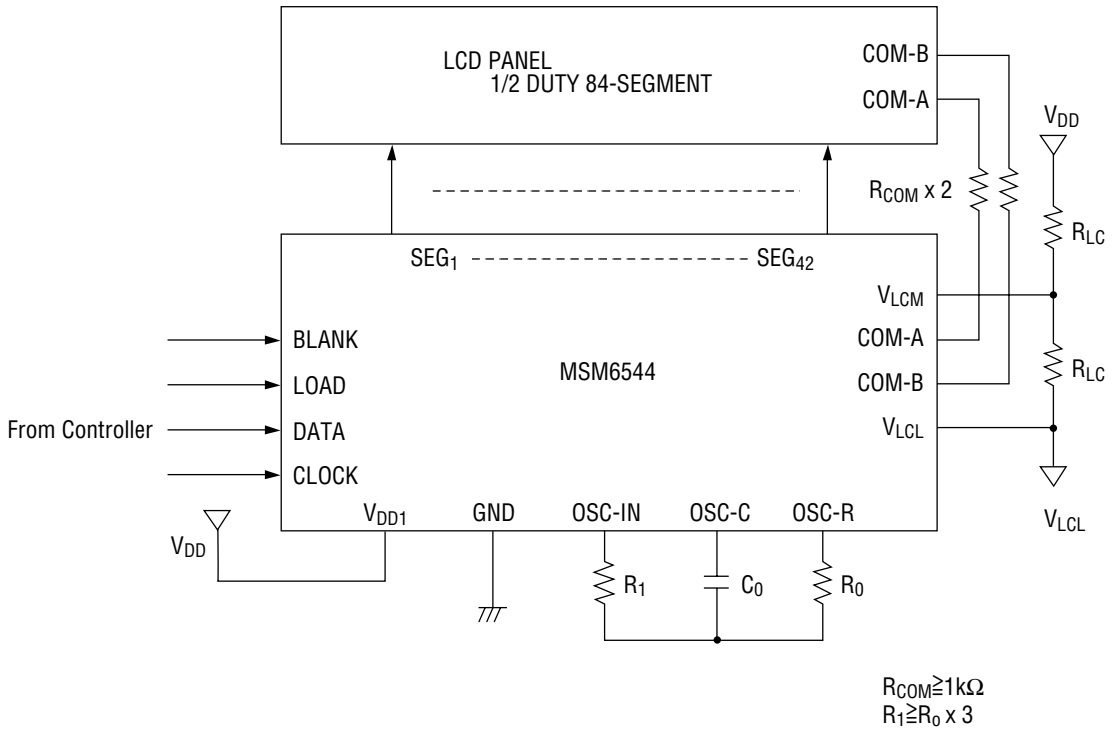

REFERENCE DATA

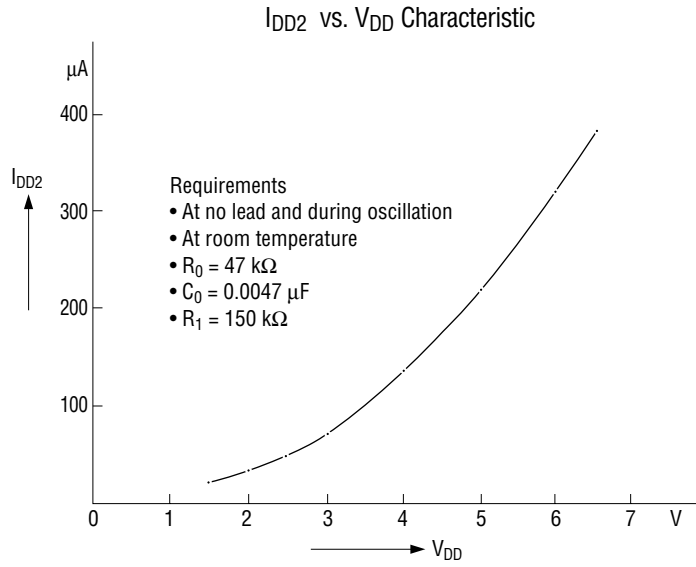

f_{COM} vs. V_{DD} Characteristics

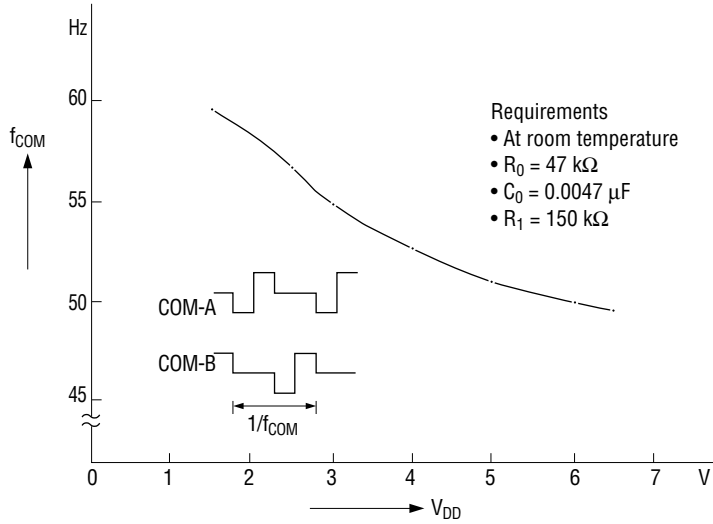

f_{COM} vs. R_0 Characteristics

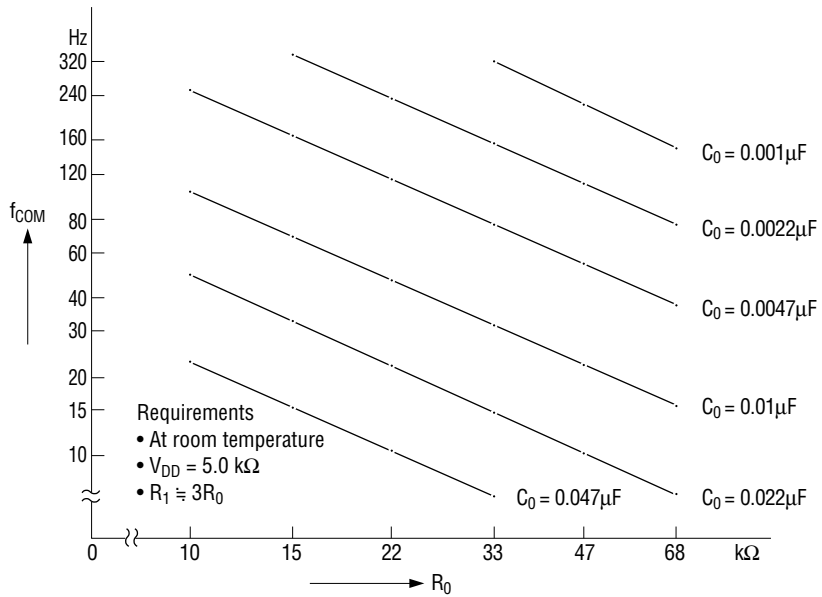

PACKAGE DIMENSIONS

(Unit : mm)

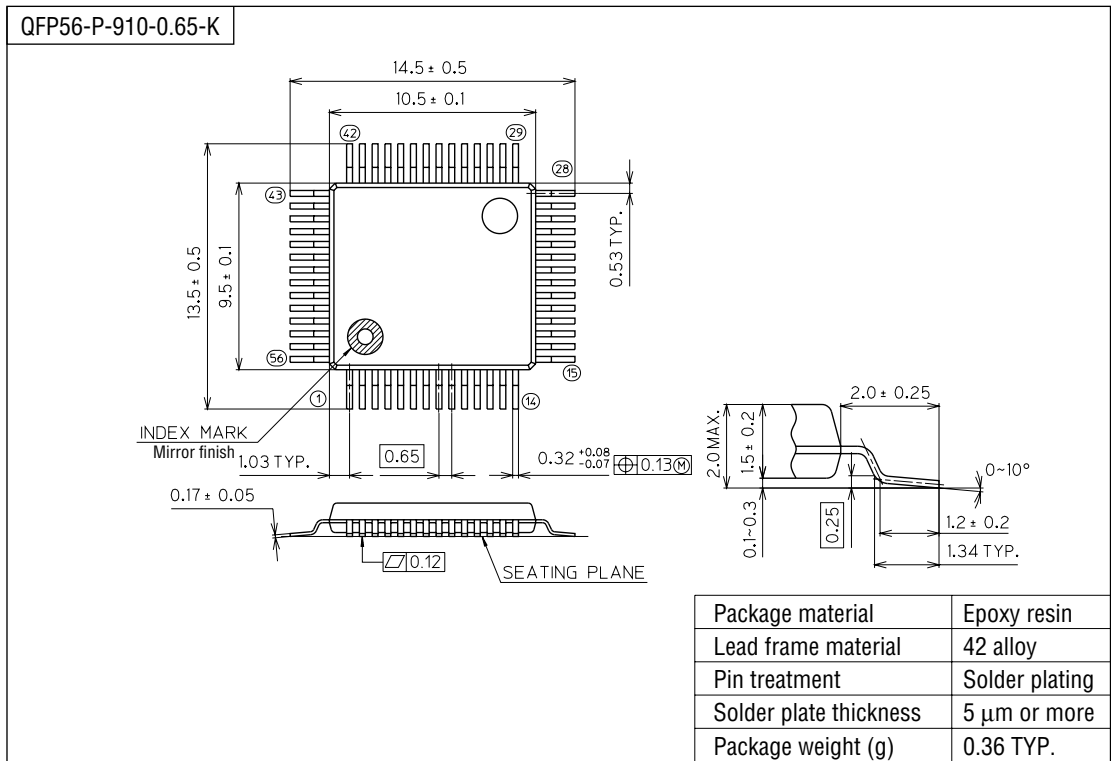

Notes for Mounting the Surface Mount Type Package

The SOP, QFP, TSOP, SOJ, QFJ (PLCC), SHP and BGA are surface mount type packages, which are very susceptible to heat in reflow mounting and humidity absorbed in storage. Therefore, before you perform reflow mounting, contact Oki's responsible sales person for the product name, package name, pin number, package code and desired mounting conditions (reflow method, temperature and times).